

Dipl.- Wirt. Ing. Ralf Metz
IWK Verpackungstechnik GmbH

NO COMPROMISE – IWK's NEW BLISTERLINE



BP5

SC5

NO COMPROMISE – IWK's NEW BLISTERLINE



300

Blister/min

200

Carton/min

Blister Packaging Machine BP 5

fully **GMP**

EASY to operate



EASY to clean

PVC and **ALU** foil possible

GMP design



- **Machine frame made of Stainless Steel**
- **Easy to clean through smooth surfaces and no openings or visible cables**

Easy operation - Base web

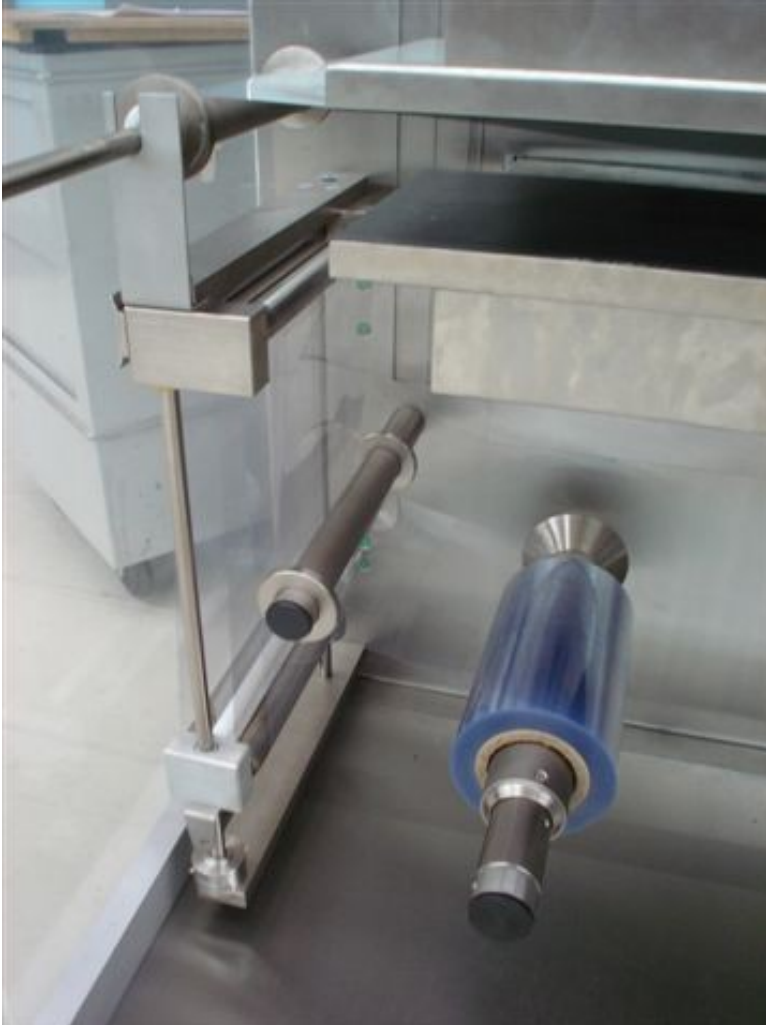

- **Easy to access and simple tension adjustment**
- **Web alignment during the machine operation**

Easy operation – Foil alignment

Base web roll

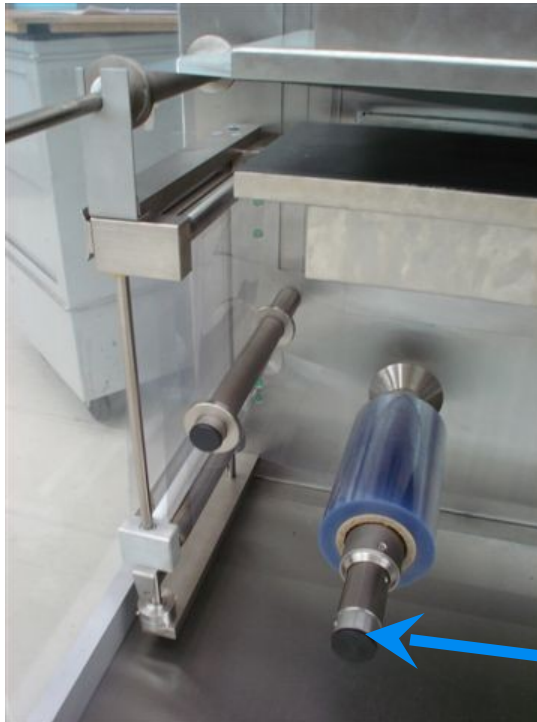

Lidding foil roll

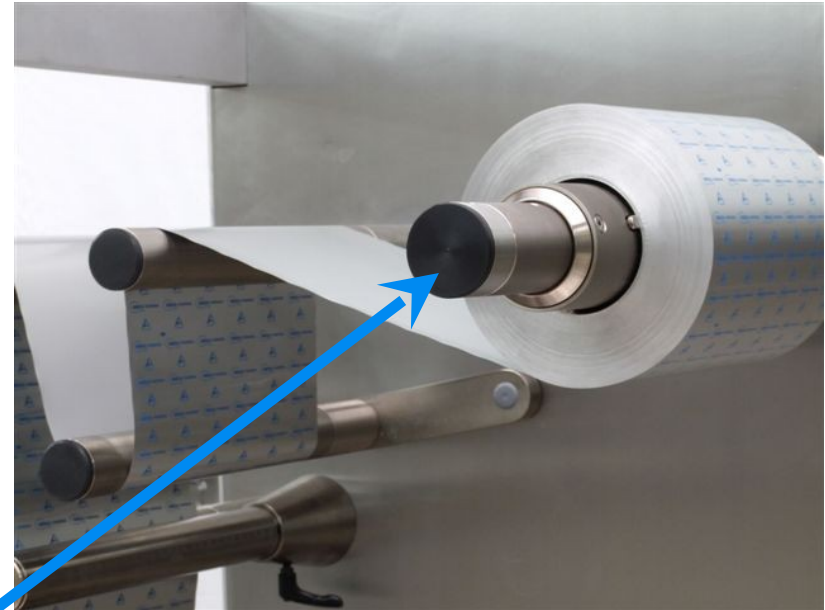

**Axial alignment of base web and lidding foil
during machine operation**

Easy operation - Heating station



- **Contact heating plates**
- **Foil protection through wide opening of plates**

Easy to operate – Tool free size change



Station details (forming / sealing)



- **Fast exchange of size parts without tools**
- **Compatible to UPS 300L toolings**
- **Forming area A (width) x B (length): 110 x 230 mm**

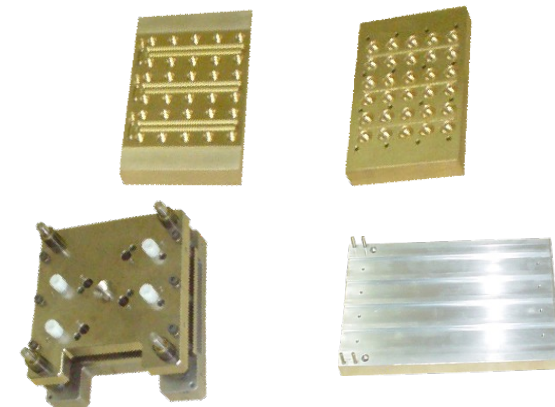

Set of size parts

Easy operation - Sealing station



- Same concept as the forming station, standardized parts
- Fast and tool-free exchange of size parts due to quick release couplings

Easy to operate - faulty blister rejection

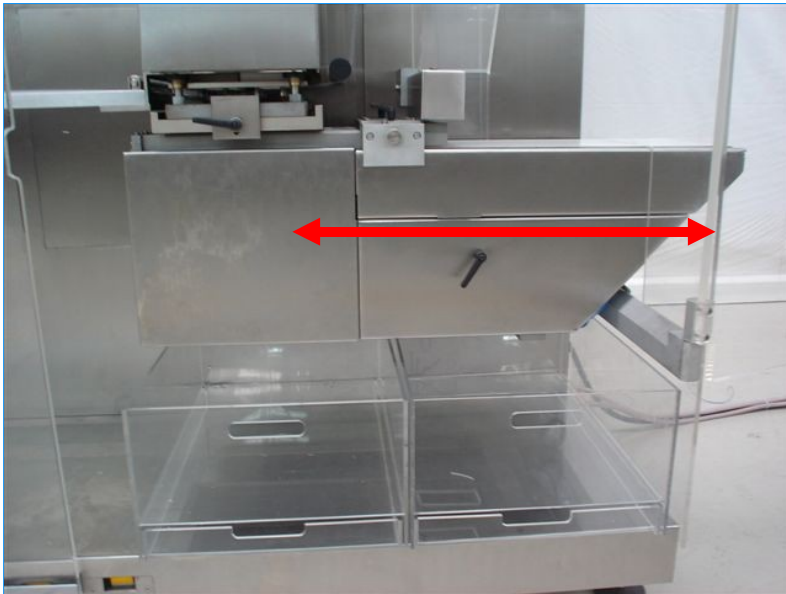

- New design concept for the rejection of faulty blisters by a movable conveyor
- Rejection of all faulty blisters in a work stroke or of individual faulty blisters in a work stroke
- **No size parts or adjustments required**

Versatility - Product feeding systems



Various product feeding systems available:

- Vibration tablet feeder with filling shoe
- Brush box feeders
- Multi colour product feeders (2 or 3 colours)
- Dedicated feeders, i. e. for Alu/Alu blisters and ampoules



Versatility - Process controls



Vision systems :

- Laetus
- Lixis
- Hypervision
- Pollux
- Others

Pinhole detectors for ALU/ALU applications



Combined thermoforming and cold forming station for PVC / ALU and ALU/ALU

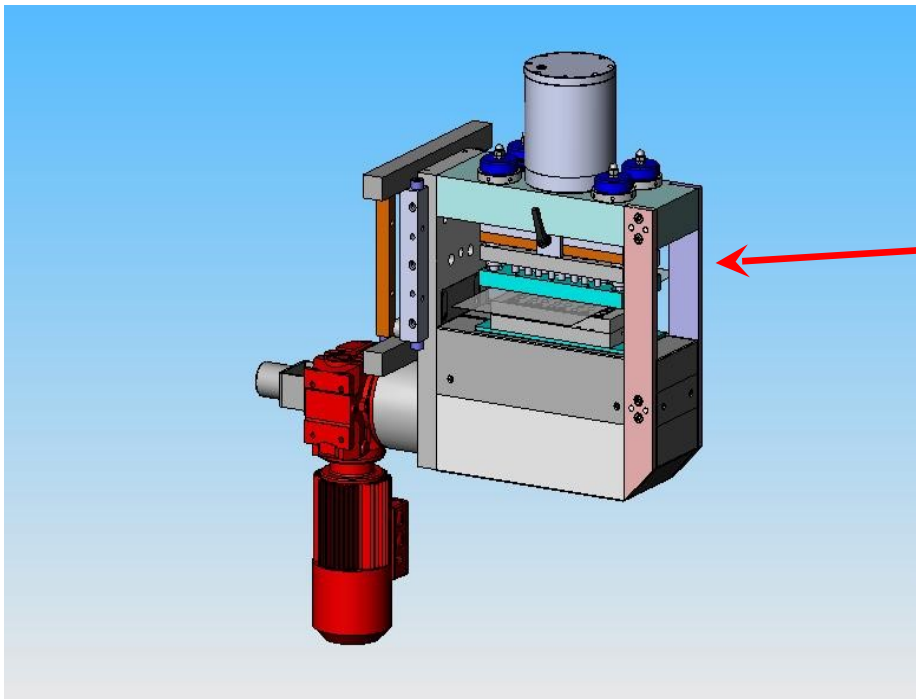

- Tool free exchange of size parts due to quick release couplings
- Four calibrated and preset spring assemblies on top of the station, easy to change
- Hot forming of PVC or cold forming of ALU base web materials in **one** station
- Cables and utility lines have been banned from the work area for a clean-cut GMP machine design

Maintenance access

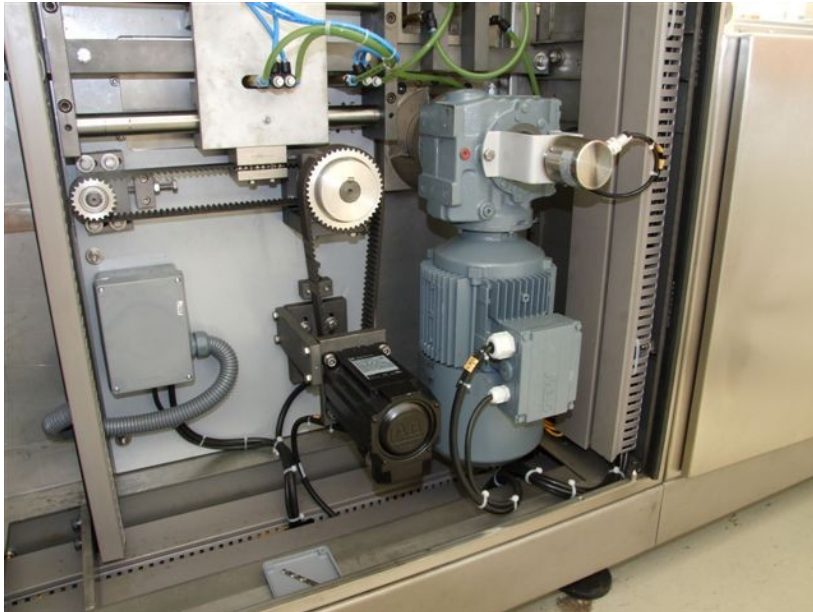

- For each individual machine drive: maintenance-free standard gearbox motors
- Mechanical parts and electrics / electronics are kept completely separated



- Electrical cabinet mounted on castors to allow free access to the mechanical machine parts
- Industrial PLC controller, servo controls and frequency converters make Allen Bradley

Applications

- Tablets
 - Sugar or film coated tablets
 - Capsules
 - Chewing gums
 - Candies
 - Jams / Marmalades
 - Ampoules
 - etc.
- Drawing depth of base web:
max. 25 mm



NEW CARTOPAC SC5
continious cartoning machine



CARTOPAC SC 5



- **Short machine footprint**
- Neat grouping of the individual machine functions
- Best work access due to large-area easy to open guarding
- Easy, reproducible size changeovers
- Touch screen operating panel
- Easy to clean

Technical data SC 5

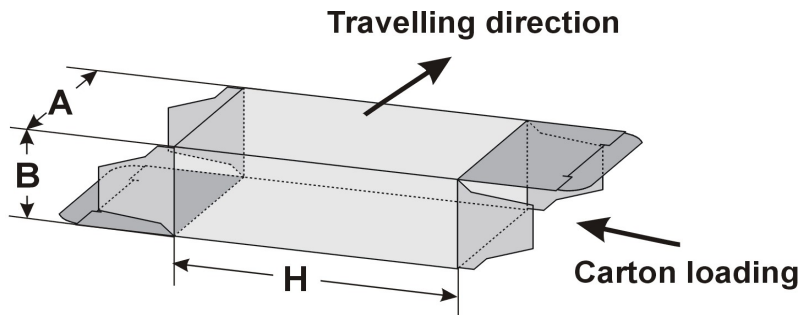

Work area (mm)

A 20 -100

B* 15 -100

H 65 - 230

*) for glue closure: 20-100 mm

Output

up to 200 cartons/min

Flexible in use

Various transfer systems adaptable for:

- **Blister**
- **Bottles**
- **Tubes**
- **Additional Applicators / Spoons / Pipettes**

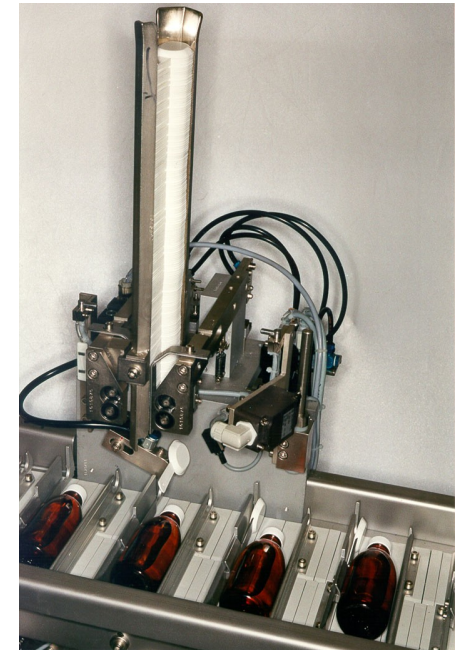
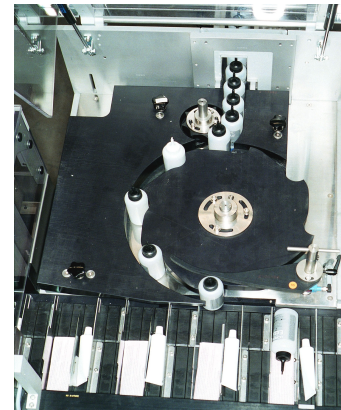
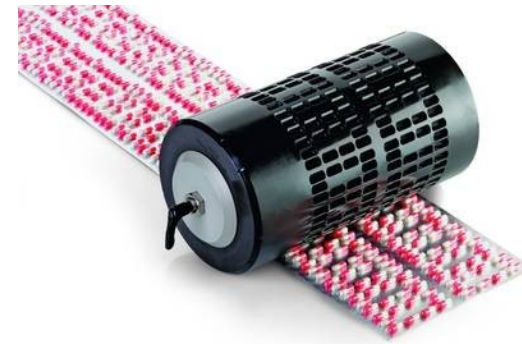

Innovative design

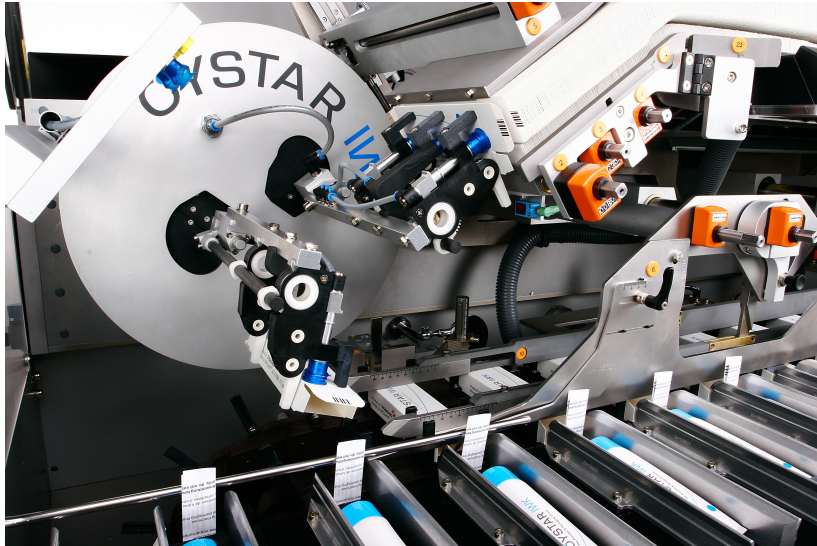

**NEW 2-arm cycloide
with advanced movement
for safe carton erection**

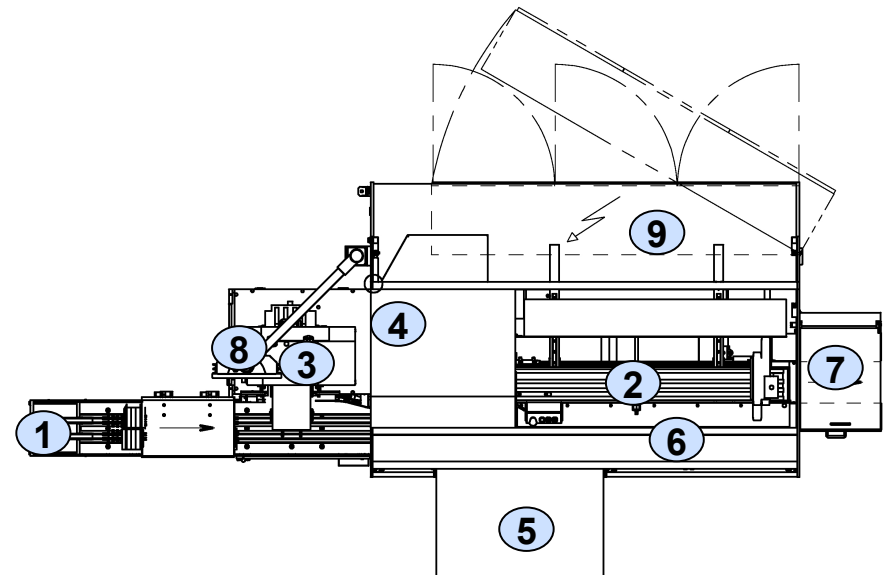

**Compact grouping
of the individual stations to
shorten the machine length**

NO COMPROMISE

**THANK YOU FOR YOUR
ATTENTION!**

RALF METZ

OYSTAR IWK

END